

**TI60-0015**

1-Phase Asynchronous Motors



**DRIVESYSTEMS**

Our Solution. Your Success.

# 1-Phase Asynchronous Motors

## 1-Phase Asynchronous Motor

1500 r/min 230V  
50 Hz 4-pole



Motor	P <sub>N</sub> [kW]	n <sub>N</sub> [r/min]	M <sub>N</sub> [Nm]	230V			cos φ	η	η	η	M <sub>A</sub> /M <sub>N</sub>	M <sub>K</sub> /M <sub>N</sub>	I <sub>A</sub> /I <sub>N</sub>	J [kgm <sup>2</sup> ]	m [kg]
				I <sub>N</sub> [A]	1/2 P <sub>N</sub> [%]	3/4 P <sub>N</sub> [%]									
63 SH/4 EST2	0,12	IE2	1420	0,81	0,96	0,88	44,2	54,6	61,5	1,8	1,8	3,4	0,00024	4	
63 LH/4 EST2	0,18	IE2	1420	1,21	1,39	0,84	45,9	59,4	66,5	1,9	1,9	3,4	0,00033	5	
71 SH/4 EST2	0,25	IE2	1450	1,65	1,59	0,89	51,5	65,9	76,7	2,4	2,1	4,8	0,00086	6,5	
71 LH/4 EST2	0,37	IE2	1445	2,45	2,26	0,95	56,6	70,1	75,1	2,3	2,0	4,9	0,00110	7,5	
80 SH/4 EST2	0,55	IE2	1445	3,63	3,20	0,94	60,5	75,3	79,1	2,1	1,8	4,7	0,00145	10	
80 LH/4 EST2	0,75	IE2	1440	4,97	4,30	0,93	66,6	77,5	81,4	2,4	2,0	4,9	0,00190	11	
90 SH/4 EST2	1,10	IE2	1430	7,35	6,15	0,93	67,8	78,8	84,3	2,0	2,0	5,0	0,00340	15,5	
90 LH/4 EST2	1,50	IE2	1440	9,95	8,40	0,94	75,9	81,2	82,8	2,1	2,0	4,8	0,00390	17	

1800 r/min 115/230V  
60 Hz 4-pole



Motor	P <sub>N</sub> [kW]	P <sub>N</sub> [hp]	Code	n <sub>N</sub> [r/min]	M <sub>N</sub> [Nm]	115V		I <sub>N</sub> [A]	cos φ	η	η	η	M <sub>A</sub> /M <sub>N</sub>	M <sub>K</sub> /M <sub>N</sub>	I <sub>A</sub> /I <sub>N</sub>	J [kgm <sup>2</sup> ]	m [kg]
						I <sub>N</sub> [A]	230V [A]										
63 LA/4 ECR1	0,12	0,16	K	1740	0,66	3,30	1,57	0,66	47,5	2,5	3,5	3,8	0,00035	4			
71 L/4 ECR1	0,18	0,25	J	1760	0,98	3,46	1,73	0,89	55,5	2,2	3,3	4,5	0,00086	6,5			
71 LA/4 ECR1	0,25	0,33	K	1750	1,36	4,80	2,40	0,69	61,6	2,1	3,0	4,5	0,00101	7,5			
80 L/4 ECR1	0,37	0,50	R	1765	2,00	6,60	3,40	0,80	65,1	2,4	3,4	5,6	0,00140	10			
80 LA/4 ECR1	0,55	0,75	P	1760	2,98	9,40	4,70	0,71	71,3	2,6	2,9	5,1	0,00190	11			
90 L/4 ECR1	0,75	1,00	R	1770	4,05	11,80	5,94	0,79	71,9	2,3	3,1	6,3	0,00313	15			
90 LB/4 ECR1	1,10	1,50	N	1765	5,95	15,30	7,62	0,85	73,3	2,1	2,9	5,7	0,00390	15,5			
90 LX/4 ECR1	1,50	2,00	M	1745	8,21	20,30	10,40	0,87	76,3	1,5	2,3	5,0	0,00390	17			

Single-phase AC motors are usually designed with two phases internally. One phase is connected directly to the supply voltage, the second phase is connected in series with a capacitor. To achieve higher starting torques, in addition to the operating capacitor, bipolar electrolytic capacitors are often used as starting capacitors, which are switched off by an electronic relay after the motor has started up. To thermally protect the relay and the starting capacitor, there should be at least 1.5 seconds between two consecutive starts and 9 starts per minute should not be exceeded. For single-phase motors with an output of 370W or more, the required pause times between two consecutive starts are largely determined by the duty cycle of the starting capacitor and must be increased accordingly. Blockages, generator operation, jog operation and lifting applications are not permitted. Please contact NORD for further support.

## 1-Phase Asynchronous Motor

Dimensions of IEC B14 and NEMA C-Face Motors

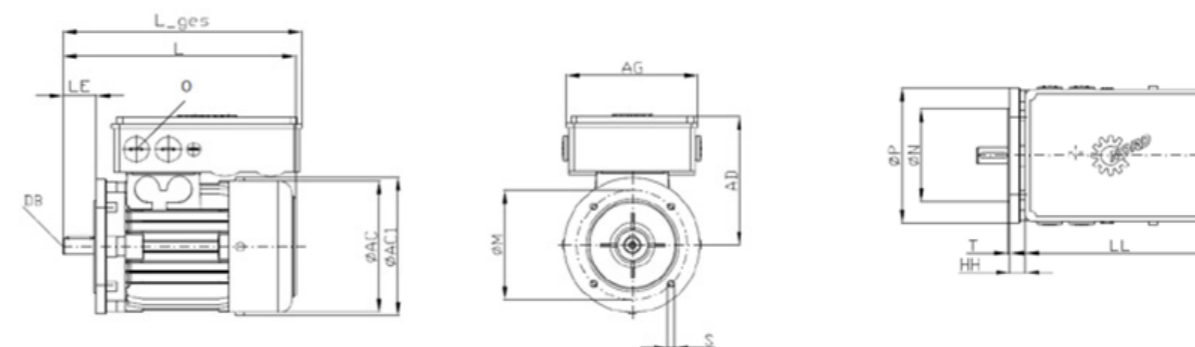

Motor	LL	AG	AD	HH	O	L ges	L
63 SH/4 EST2	225	156	151	1	M25x1,5	249	215
63 LH/4 EST2	225	156	151	1	M25x1,5	249	215
71 SH/4 EST2	225	156	160	9	M25x1,5	264	244
71 LH/4 EST2	225	156	160	9	M25x1,5	264	244
80 SH/4 EST2	225	156	153	18	M25x1,5	283	276
80 LH/4 EST2	225	156	153	18	M25x1,5	283	276
90 SH/4 EST2	225	156	170	22	M25x1,5	326	326
90 LH/4 EST2	225	156	170	22	M25x1,5	326	326

Motor	LL	AG	AD	HH	O	L ges	L
63 LA/4 ECR1	225	156	151	1	3/4"	278.6	244.6
71 L/4 ECR1	225	156	160	9	3/4"	286.3	266.3
71 LA/4 ECR1	225	156	160	9	3/4"	286.3	266.3
80 L/4 ECR1	225	156	153	22	3/4"	299.3	292.3
80 LA/4 ECR1	225	156	153	22	3/4"	299.3	292.3
90 L/4 ECR1	225	156	170	26	3/4"	333.8	333.8
90 LB/4 ECR1	225	156	170	26	3/4"	333.8	333.8
90 LX/4 ECR1	225	156	170	26	3/4"	333.8	333.8

All specifications in mm unless otherwise indicated.

All non-listed dimension like standard 3-phase IE3 4-pole asynchronous motor of same frame size. See M7000.

## EN

Headquarters  
Getriebebau NORD GmbH & Co. KG  
Getriebebau-Nord-Str. 1  
22941 Bargteheide, Deutschland  
T: +49 45 32 / 289 0  
F: +49 45 32 / 289 22 53  
info@nord.com